

Paragon Door
vertical cross section

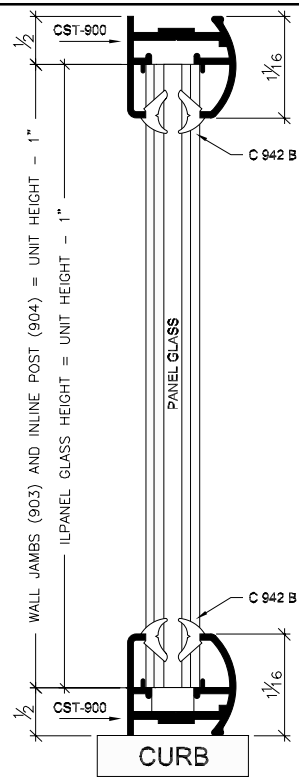

Inline Panel
vertical cross section

NOTES:

1. FORMULAS ARE BASED ON A MINIMUM WIDTH OPENING. WHEN MEASURING OPENING WIDTHS, ALWAYS CHECK FOR OUT OF PLUMB WALL CONDITIONS.
2. STANDARD DOOR WIDTH ADJUSTMENT IS (+) 3/4 OF AN INCH. THE 3/4 INCH IS GAINED BY ADJUSTING STRIKE AND HINGE METALS (926 & 920) WITHIN THEIR RESPECTIVE JAMBS (903 & 904) AS SHOWN IN HORIZONTAL CROSS VIEW.

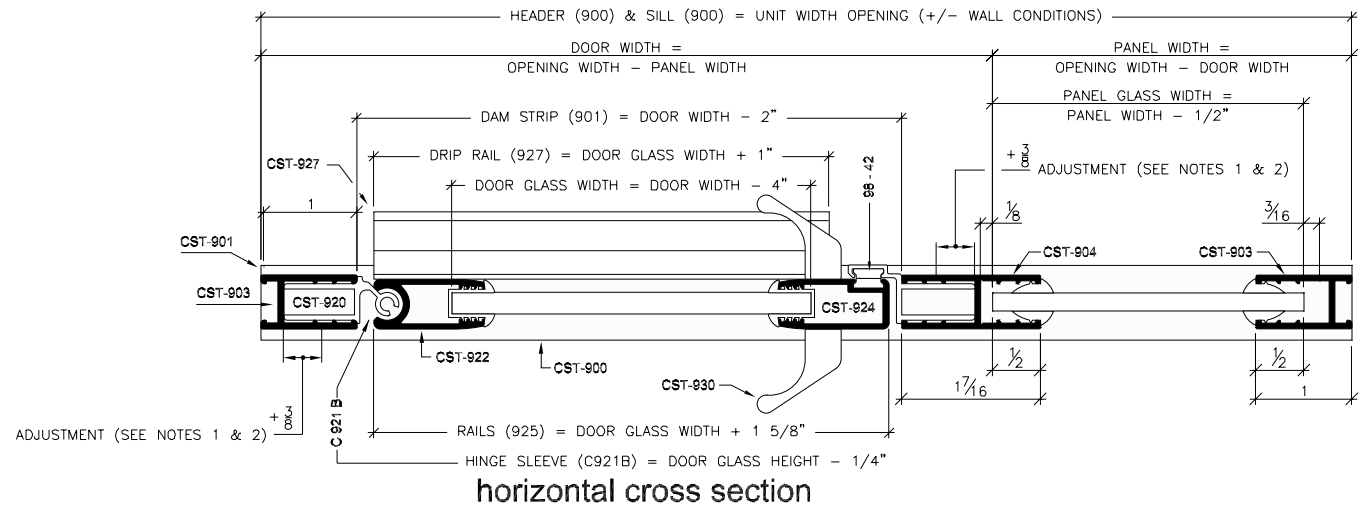

horizontal cross section

Series

Unit Configuration

PARAGON

Door w/ 1 Inline Panel



Coastal Industries Inc.